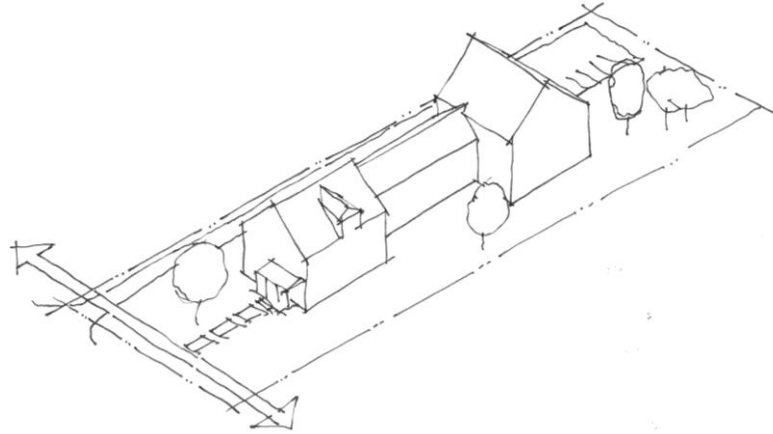

SECTION 16.4 DEVELOPMENT STANDARDS FOR SITES AND BUILDINGS**16.40 General Development Standards for Sites and Buildings**

The following general development standards for sites and buildings are applicable to all Form-Based Districts (FBD), except where specifically modified in district subsections below. FBD established subsequently may be added to further define the standards of future districts:

- 16.400 General Development and Design Principles – This section is intended to guide development of site and building design. These principles and standards are intended to encourage creativity, invention and innovation while maintaining the village center character of the FBD. There is no prescribed architectural or aesthetic style for the districts, but a series of general development principles and standards that apply to all actions reviewable under this section.
- 16.401 General Development Appearance – The character, layout and general composition of the site, including but not limited to the type, color and texture of materials used in plantings, paving, lighting, furnishing, signage, utility structures and all other appurtenant elements shall harmonize with the building design.
- 16.402 Façade Length and Articulation – Buildings or portions of a building with front elevations of over 50 feet in length shall be divided into smaller parts through pronounced variation in wall plane articulation and materials and variations in the cornice/roofline to accomplish the desired visual divisions of elevations into smaller parts. Building articulations shall be 12 inches or more in depth. Use of façade divisions, such as building jogs, architectural detailing, and changes in surface materials, colors, textures and roof lines is highly recommended. Uninterrupted facades shall not exceed 50% of the building wall, and in no case shall an uninterrupted wall expanse exceed 50 feet in length. All façades of a building which are visible from public streets shall feature characteristics similar to the front façade.
- 16.403 Building Separation – Multiple structures on the same site shall comply with Article 3 Section 3.01 and shall be separated by not less than 20 feet between buildings. Separation and configuration of buildings on the site shall allow for vehicle and pedestrian access to the rear of the site.
- 16.404 Building Entrances – Development and redevelopment shall include building façades that front on and have a principal pedestrian entrance oriented to public streets. The construction of any new buildings shall provide the creation of pedestrian alleyways, where appropriate, in order to allow for passageways to parking at the rear of the lots and adjoining streets.
- 16.405 Incorporate Architectural Features – The use of architectural features and details such as porches, awnings, columns, dormers, skylights and arches shall be used to create visually dynamic and interesting buildings. The definition of street corners with building form and architectural features is important to anchoring the building on the site and framing the street.

-
- 16.406 Transparency – Transparency is the percentage of windows and doors that cover a ground or upper story façade. Door and window openings shall be proportional to façade length and height. The building design shall create a sense of entry into the site through landscaping, façade treatment and signage. New non-residential development shall provide ground floor windows along street façades, including windows that allow views into working areas or lobbies, pedestrian entrances, or display windows.
- 16.407 Front Porches or Articulation of Entries – Front porches may extend up to 10 feet into street yards provided they are at least 8 feet deep. Partial walls, screened areas, and railings on porches that extend into the street yard may be no higher than 42 inches.
- 16.408 Building Roof Form and Features – Long unbroken expanses of roofs shall be avoided through the use of dormers, skylights, chimneys and changes in ridge line. Flat roofs shall not be permitted for one story buildings unless the front elevation is at least 15 feet in height. Flat roofs are permitted for only larger format commercial structures. All other roof forms shall be pitched. Where pitched roofs are used, a 6 in 12 inch pitch or greater is encouraged. Accessory rooftop equipment shall not extend more than four (4) feet above the allowed building height provided that they are set back from the exterior wall(s) by at least 10 feet, and are enclosed or screened by a parapet, or with materials compatible with the building so as not to be visible from the ground. Accessory equipment shall not exceed 20% of the roof area. Where head house structures are necessary, they shall not exceed eight (8) feet in height, shall be setback from the exterior wall(s) by at least 10 feet, and shall not exceed 20% of the roof area.
- 16.409 Ground Story Heights – The ground story of commercial and mixed-use buildings must be from 12 feet to 18 feet tall. The ground story of residential and live-work buildings must be from 10 to 14 feet tall. Each story above the ground story in commercial and residential buildings must be from 8 feet to 12 feet tall; any upper story taller than 12 feet will count as two stories. Story heights are measured from the floor to the bottom of the lowest structural member that supports the story above. Residential buildings must have their first habitable floor raised at least 2½ feet above the adjacent sidewalk. If the first floor is more than 5 feet above the adjacent sidewalk, the space below the first floor counts as the ground (first) story.
- 16.4010 Driveways and Garages – Detached garages shall always be located in the rear of the lot. All walls of attached garages shall be at least 20 feet behind the principal plane of the house’s primary façade. Garage doors shall face the side or the rear of the site rather than the streetyard. Where space does not permit a side- or rear-facing garage door, front-facing garage doors may be provided but each door shall not exceed 10 feet in width. Driveways shall serve as access to a minimum of three (3) dwelling units and may not exceed 12 feet in width except at the garage entrance.
- 16.41 Additional Development Standards for North Amherst Village Center (NAVC)
- The following development standards for sites and buildings are specific to the North Amherst Village Center and are not applicable to other FBD:
- 16.410 In North Amherst Village Center, the village residential character is comprised largely of a connected farm-house configuration of buildings. To maintain this sense of character,
-

new residential forms located upon Village Residential Streets (See Section 16.2) shall follow a similar composition including distinct building masses with pitched roofs that frame shared open spaces and are oriented with the short side of the building configuration facing the primary public street. The distinct building masses may be either connected or independent. The primary entry shall be oriented to the street with a connection to the sidewalk and articulation of the entry.



The arrangement of adjacent village residential buildings of this type shall incorporate shared driveways, parking areas and walkways ensuring the preservation of open space. Adjacent structures shall provide variety and visual interest in the composition of building masses through variation in the orientation of gable ends and roof ridges. Pedestrian circulation shall be provided from all parking areas to building entrances and connecting to the sidewalk at the street. Pedestrian circulation along the public way shall be uninterrupted and continuous.

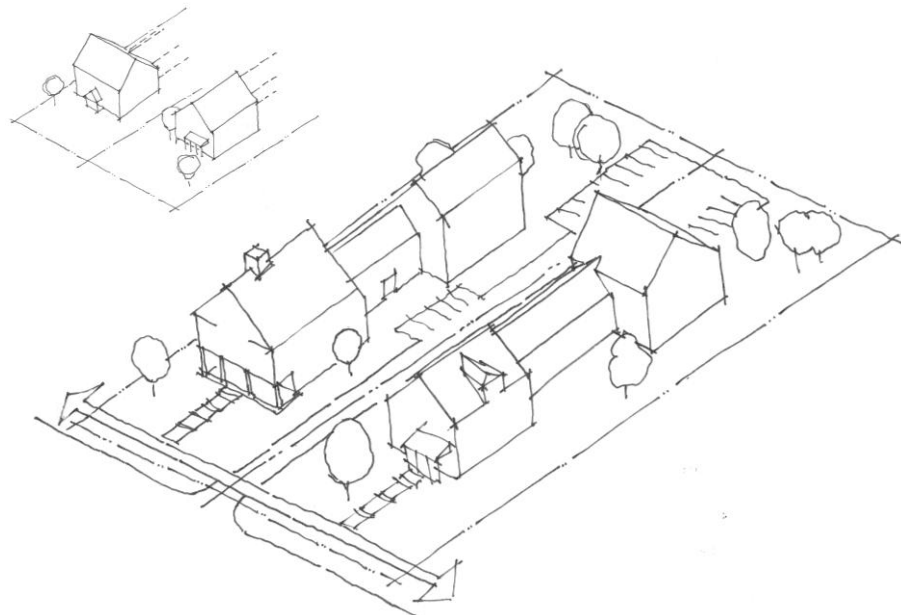

16.411 In North Amherst Village Center, the character of Commercial Street Types (See Section 16.2) shall be maintained by locating parking and loading to the sides and rear of buildings. Building frontages facing primary streets shall be developed as outdoor

activity zones or landscaped entry areas. The pedestrian circulation shall be buffered from traffic along the primary street with landscaping and street trees. Pedestrian circulation shall be continuous and uninterrupted and provide access from all parking areas to the building entries. Parking areas shall be screened and buffered with buildings and landscaping.

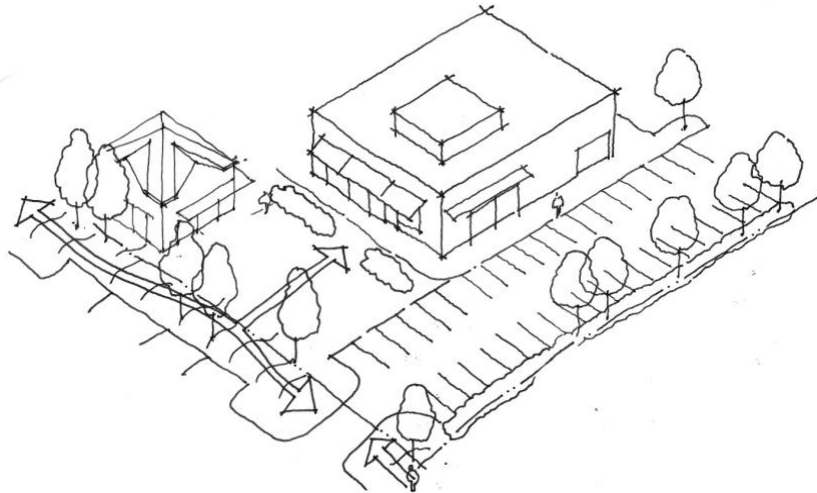

16.42 Additional Development Standards for Atkins Corners (AC)

The following development standards for sites and buildings are specific to the Atkins Corners and are not applicable to other FBD:

16.420 A critical component to building upon and enhancing the character of Atkins Corners is ensuring the physical definition and emphasis of street corners with future development components. New buildings and building features shall define street corners and anchor the building on the site through architectural articulation or variation in building massing, form or roof. Parking areas shall not be placed at street corners and prominent intersections. Continuous pedestrian circulation shall reinforce the definition of corners and provide safe pedestrian crossing at streets. Landscaping and street trees shall be used to reinforce the importance of the corner, frame views and screen parking areas.

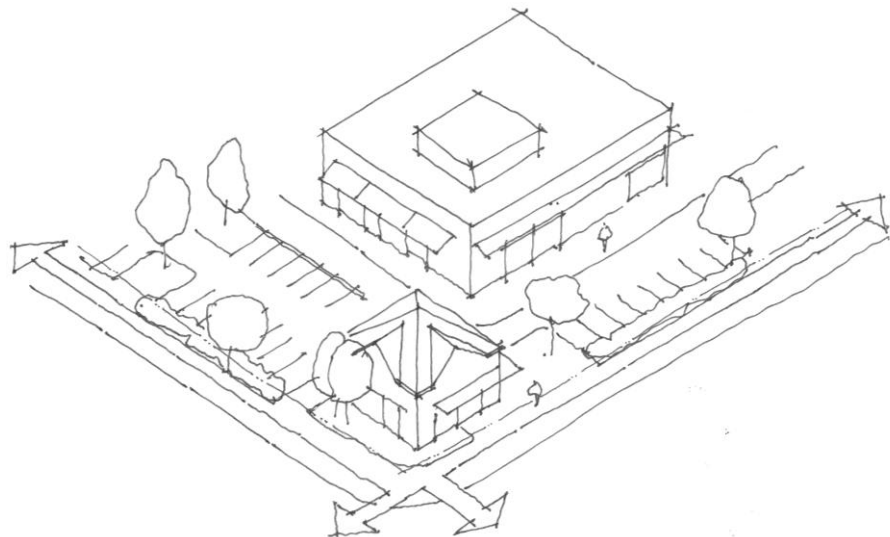

Alternatively, corners may be defined by the void between buildings. This space shall be used as a public entry plaza for buildings and pedestrian circulation into the site. Although the corner is open, the buildings shall be configured to define a continuous street edge and the edges of the corner open space.

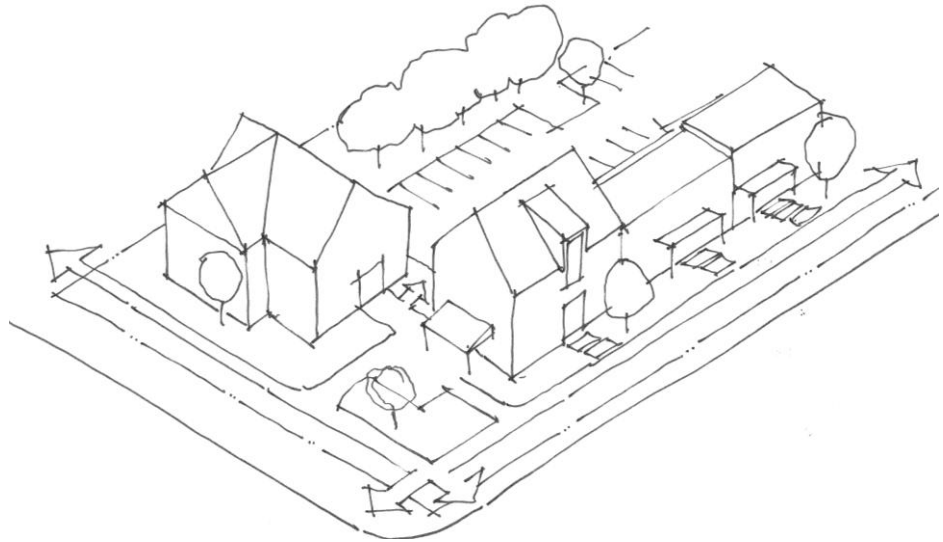

- 16.421 New development and redevelopment in Atkins Corner shall place parking and loading areas to the side or rear of buildings and away from prominent corners or street frontages. Parking and loading areas shall be buffered with landscaping. Pedestrian circulation shall be continuous and uninterrupted along streets and providing access to building entries and all parking areas. Buildings shall be arranged to form consistent street frontages and define street edges and alignments.

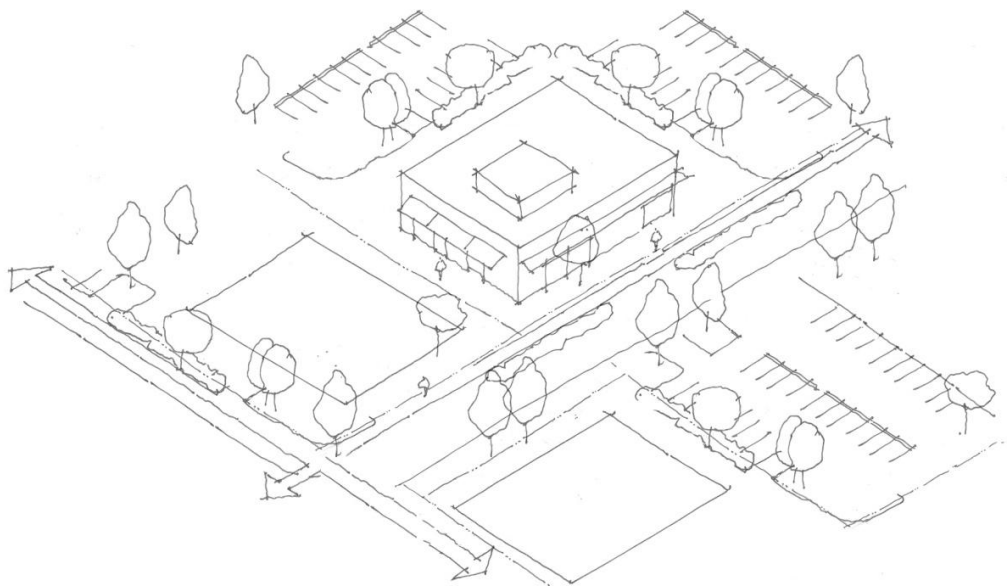

16.422 The landscape features at Atkins Corners shall be used as an opportunity to differentiate the character of the village center with an emphasis on agricultural landscape, types of plantings and layouts (for example a grove of apple trees), and mixed hardwoods. New landscaping shall incorporate a minimum of 25% of its landscape materials into an agricultural theme that is appropriate to the site and to the heritage of Atkins Corners.

16.43 Additional Development Standards for Educational Form Overlay District (ED-F)

The following development standards for sites and buildings are specific to the Educational Form Overlay District (ED-F) and are not applicable to other FBD. The development standards that follow, in this Sub-section 16.43 and the standards outlined in Sub-section 16.42 Atkins Corners shall be the only standards of Section 16.4 that shall apply to the Educational Form Overlay District (ED-F):

16.430 The ED-F zone shall provide a consistent treatment of the street, street edge, landscape buffer, sidewalks, pedestrian and bicycle connections as is required in the adjacent Atkins Corners (AC) Form-Based District. A continuous uninterrupted sidewalk shall be provided at the street making connections to adjoining properties and crosswalks to improve connectivity along public ways for pedestrians in Atkins Corners.